



# SI

Series  
450 pound

Extractor  
Washer



# Powerful, Efficient, Affordable

*The SI-450 - Outstanding reliability and efficiency at a price you can afford*

The SI-450 is ideally suited for around the clock operation. Automatic operation has never been more affordable! All wetted components are of 304 stainless steel, meaning long life and chemical resistance. Maintenance is fast and easy, with unsurpassed access to all the internal components. The bearings are located away from the wash area, so no damage will occur in the event of a seal leak.

## Powerful Control Center

Our user friendly industrial controller provides the ultimate in reliability and power. The alpha-numeric display is easy to read and displays the formula name, step, temperature, water level and time - in five languages.



## Safe & Strong Door Lock

The powerful industrial door lock provides safety and peace of mind for the life of the equipment and ensures that the door may only be opened when the machine is not running. Double fail safe protection is standard, and servicing is simple.



## Hydraulic Tilt and Door

Automating your laundry is fast and easy! The door can automatically open at the end of a cycle, and in conjunction with the hydraulic tilt feature makes loading and unloading a breeze!

## Superb Strength and Design

Heavy duty industrial components are used throughout the system. Fully enclosed hostile duty motor is virtually immune to damage caused by dirt and lint. Cast iron pulley provides years of trouble free service. All welded heavy duty steel frame has been rigorously tested for strength and endurance under extreme conditions.

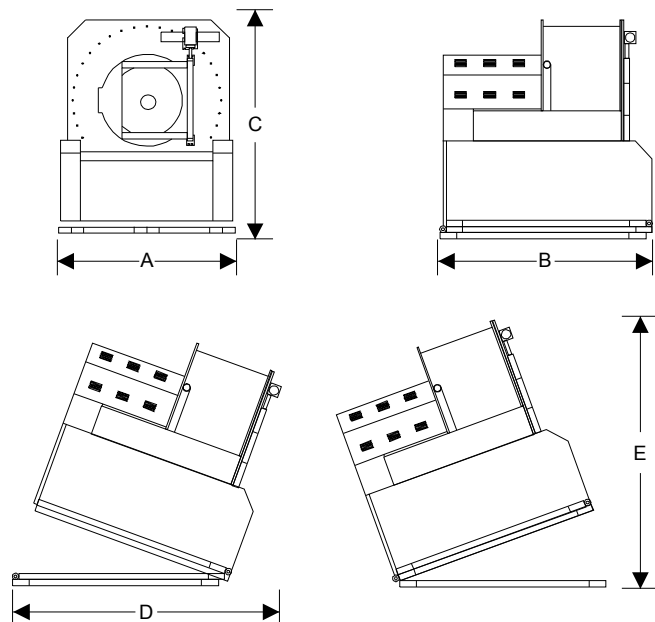

Capacity - Up to	Lbs	Kg	475	215
Loading factor 1:10	Lbs	Kg	472	213.5
Loading factor 1:12	Lbs	Kg	391.9	177.9
Loading factor 1:13	Lbs	Kg	361.7	164.2
<b>Overall Dimensions:</b>				
Width - A	Inch	mm	91.8	2332
Depth - B	Inch	mm	106.3	2700
Height - C	Inch	mm	108.9	2766
<b>Tilted dimensions-Maximum</b>				
Width - A	Inch	mm	91.8	2332
Depth - D	Inch	mm	152.8	3880
Height - E	Inch	mm	128.7	3269
<b>Cylinder Information</b>				
Diameter	Inch	mm	64	1625
Depth	Inch	mm	40.5	1028
Volume	cuft	liters	75.4	2135
Perforation Size	Inch	mm	0.1875	4.76
Perforation Open Area	%	%	22	22
<b>Cylinder Speeds (Programmable)</b>				
Wash	rpm	rpm	30	30
High Extract	rpm	rpm	595	595
<b>Centrifugal Forces (Programmable)</b>				
Wash	G	G	0.8	0.8
High Extract	G	G	320	320
<b>Door Opening and Height</b>				
Diameter	Inch	mm	40.2	1020
Height of door bottom above floor (non tilt version)	Inch	mm	47.25	1200
<b>Drive Information</b>				
Number of drive motors			1	1
Drive motor	HP	kW	40	29
Tilt motor (Hydraulic unit)	HP	kW	5	3.7
<b>Utility Connections</b>				
Water inlets	Inch	DN	2	50
Drain Outlet	Inch	mm	5	125
Steam Inlet	Inch	DN	1-1/4"	32
Air inlet	Inch	DN	0.5	15
<b>Electrical Service</b>				
200-240V 50/60Hz 3 phase 3 wire	Amp	Breaker	92	100
380-480V 50/60Hz 3 phase 3 wire	Amp	Breaker	60	75
<b>Weight and Shipping Information</b>				
Net Weight	Lbs	Kg	18500	8400
Domestic Shipping Weight	Lbs	Kg	18750	8520
Domestic Shipping Volume	cuft	m3	630	17.8
Export Shipping Weight	Lbs	Kg	18825	8550
Export Shipping Volume	cuft	m3	642	18.2

Specifications are subject to change without notice

## Accurate Technologies

Bangkok, Thailand  
 Phone: 662-671-1358  
 FAX: 662-671-1361  
[www.accuratethai.com](http://www.accuratethai.com)  
[info@accuratethai.com](mailto:info@accuratethai.com)

## B&C Technologies

Panama City, FL 32401  
 Phone: 850-249-2222  
 FAX: 850-249-2226  
[www.bandctech.com](http://www.bandctech.com)  
[sales@bandctech.com](mailto:sales@bandctech.com)